

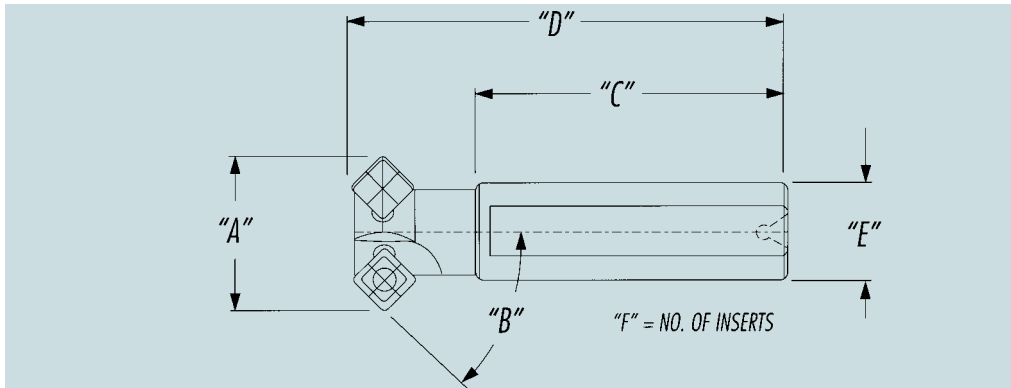

INDEXABLE ChamferMills



THESE PRECISION, INDEXABLE CHAMFERING TOOLS DELIVER PRECISE BEVELING CUTS IN STANDARD MILLING OPERATIONS. Special diameters are available upon request.

- PRECISION-GROUND INDEXABLE INSERTS
- ADAPTABLE TO ANY MACHINING OR TURNING CENTER
- RIGID ONE-PIECE CONSTRUCTION
- HIGH-STRENGTH DESIGN FOR DEPENDABLE PERFORMANCE

TOOL NO.	INSERT NO.	SCREW NO.	A	B	C	D	E	F
TF 06378	SPGT 32.52	TF 04754	1.000	45 DEG	2.000	3.000	.7495	1
TF 06379	SPGT 32.52	TF 04754	1.250	45 DEG	2.500	3.500	.7495	2
TF 06380	SPGT 32.52	TF 04754	1.500	45 DEG	2.500	3.500	.7495	3
TF 06381	SPGT 432	TF 04755	2.000	45 DEG	2.750	4.000	.9995	3
TF 06382	SPGT 32.52	TF 04754	1.250	15 DEG	2.500	3.500	.7495	2
TF 06383	SPGT 32.52	TF 04754	1.250	30 DEG	2.500	3.500	.7495	2

Note: All inserts are TiN-coated.